

JP2000-310759E

[Title of the Invention] APPARATUS AND METHOD FOR
 MANUFACTURING LIQUID CRYSTAL DISPLAY DEVICE

[Abstract]

[Object] To realize an apparatus for manufacturing liquid crystal display devices capable of precisely joining two substrates which are opposed to each other without destruction of the substrates.

[Solving Means] An apparatus for manufacturing a liquid crystal display device in which a lower substrate 3 whose upper surface is coated with an adhesive 1 and to which a liquid crystal material 2 is dropped is arranged in a vacuum container C at atmospheric pressure, the whole lower surface is fixed by vacuum suction, an upper substrate 6 is arranged so as to be opposed to the lower substrate 3 at a prescribed interval, the whole upper surface is fixed by vacuum suction, both the substrates or either one of them are approached so as to bring into contact with each other, and both the substrates 3 and 6 are pressurized to join the substrates, wherein a plurality of suction systems 7a and b are equipped in a suction mechanism 7 which performs vacuum suction on the whole upper surface of the upper substrate 6 and a suction force is controlled when fixing the upper substrate 6 by the suction force at atmospheric pressure so that possible destruction of the upper substrate 6 can be

prevented.

[Claims]

[Claim 1] An apparatus for manufacturing a liquid crystal display device in which a lower substrate whose upper surface is coated with an adhesive and to which a liquid crystal material is dropped is arranged in a vacuum container at atmospheric pressure, the whole lower surface is fixed by vacuum suction, an upper substrate is arranged so as to be opposed to the lower substrate at a prescribed interval, the whole upper surface is fixed by vacuum suction, both the substrates or either one of them are approached so as to bring into contact with each other, and both the substrates are pressurized to join the substrates, wherein a plurality of suction systems are equipped in a suction mechanism by which the whole upper surface of the upper substrate is fixed by vacuum suction.

[Claim 2] The apparatus for manufacturing a liquid crystal display device according to Claim 1, wherein both suction systems have a structure that aperture ratio of a suction hole in vacuum is larger than at atmospheric pressure.

[Claim 3] The apparatus for manufacturing a liquid crystal display device in which a lower substrate whose upper surface is coated with an adhesive and to which a liquid crystal material is dropped is arranged in a vacuum

container at atmospheric pressure, the whole lower surface is fixed by vacuum suction, an upper substrate is arranged so as to be opposed to the lower substrate at a prescribed interval, the whole upper surface is fixed by vacuum suction, both the substrates or either one of them are approached so as to bring into contact with each other, and both the substrates are pressurized to join the substrates, wherein a plane-controlled suction transfer mechanism which controls the whole surface of the substrates to be a flat plane at atmospheric pressure is equipped.

[Claim 4] The apparatus for manufacturing a liquid crystal display device in which a lower substrate whose upper surface is coated with an adhesive and to which a liquid crystal material is dropped is arranged in a vacuum container at atmospheric pressure, the whole lower surface is fixed by vacuum suction, an upper substrate is arranged so as to be opposed to the lower substrate at a prescribed interval, the whole upper surface is fixed by vacuum suction, both the substrates or either one of them are approached so as to bring into contact with each other, and both the substrates are pressurized to join the substrates, wherein a method of curing the adhesive in the vacuum container after pressurizing the upper substrate and lower substrate is installed.

[Claim 5] The apparatus for manufacturing a liquid

crystal display device according to Claim 4, wherein ultraviolet ray irradiation method is provided for adhesive curing.

[Claim 6] The apparatus for manufacturing a liquid crystal display device according to Claim 4, wherein the adhesive curing at atmospheric pressure is provided as a adhesive curing method.

[Claim 7] The apparatus for manufacturing a liquid crystal display device in which a lower substrate whose upper surface is coated with an adhesive and to which a liquid crystal material is dropped is arranged in a vacuum container at atmospheric pressure, the whole lower surface is fixed by vacuum suction, an upper substrate is arranged so as to be opposed to the lower substrate at a prescribed interval, the whole upper surface is fixed by vacuum suction, both the substrates or either one of them are approached so as to bring into contact with each other, and both the substrates are pressurized to join the substrates, wherein the vacuum suction of the whole upper surface of the upper substrate is carried out by a suction mechanism equipped with a plurality of suction systems.

[Claim 8] An apparatus for manufacturing a liquid crystal display device in which a lower substrate whose upper surface is coated with an adhesive and to which a liquid crystal material is dropped is arranged in a vacuum

container at atmospheric pressure, the whole lower surface is fixed by vacuum suction, an upper substrate is arranged so as to be opposed to the lower substrate at a prescribed interval, the whole upper surface is fixed by vacuum suction, both the substrates or either one of them are approached so as to bring into contact with each other, and both the substrates are pressurized to join the substrates, wherein a plane-controlled suction transfer mechanism controls the whole surface of the substrates to be a flat plane and performs a suction transfer at atmospheric pressure.

[Claim 9] An apparatus for manufacturing a liquid crystal display device in which a lower substrate whose upper surface is coated with an adhesive and to which a liquid crystal material is dropped is arranged in a vacuum container at atmospheric pressure, the whole lower surface is fixed by vacuum suction, an upper substrate is arranged so as to be opposed to the lower substrate at a prescribed interval, the whole upper surface is fixed by vacuum suction, both the substrates or either one of them are approached so as to bring into contact with each other, and both the substrates are pressurized to join the substrates, wherein the adhesive is cured in the vacuum container after pressurizing the upper substrate and lower substrate.

[Detailed Description of the Invention]

[0001]

[Technical Field of the Invention]

The present invention relates to an apparatus and method for manufacturing a liquid crystal display device which is used as an image display panel for personal computers or television sets.

[0002]

[Description of the Related Art]

A conventional method for manufacturing a liquid crystal display device will be described with reference to Figs. 7 to 10.

[0003]

In the structure of the liquid crystal display device, as shown in Fig. 7, a regular gap is held between a lower substrate 11 and an upper substrate 12 which are opposed to each other and consist of light-penetrating material, an electrically charged liquid crystal material 13 is filled in the gap, and both the substrates 11 and 12 are joined with each other by an ultraviolet ray curing type adhesive 14. The adhesive 14 contains a spacer 12 for holding a regular interval (a diameter of 5 μm) between the upper substrate 12 and the lower substrate 11.

[0004]

As a method for arranging a liquid crystal material 13 in the adhesive 14, as shown in Fig. 8, there is a liquid crystal dropping method including coating the adhesive 14 on

the lower substrate 11 with a thickness of 30 μm (process a), dropping the liquid crystal material 13 in the adhesive 14 (process b), superposing the upper substrate 12 on the lower substrate 11 and pressurizing both the substrates 11 and 12 until the interval between the upper substrate 12 and the lower substrate 11 becomes 5 μm (process c), and then curing the adhesive 14 by ultraviolet rays 16 (process d) to complete a liquid crystal display device.

[0005]

Hereinafter, a method for joining the two substrates will be described in detail with reference to Figs. 9 and 10.

[0006]

First, the lower substrate 11 whose upper surface is coated with an ultraviolet ray curing type adhesive 14 with a thickness of 30 μm and to which a liquid crystal material 13 is arranged in the adhesive 14 is mounted on a horizontally movable table 17, and the whole lower surface of the lower substrate 11 is fixed by a vacuum suction force of a suction mechanism 18 (process a).

[0007]

Next, the upper substrate 12 which consists of light-penetrating material is fixed by a vacuum suction force of a suction mechanism 19, a vacuum container C is closed, and the suction mechanism 19 is vertically lowered so that the upper substrate 12 is brought into contact with the liquid

crystal material 13 or the adhesive 14 (process b). Next, the table 17 having the lower substrate 11 mounted thereon is moved in a horizontal direction, so that the upper substrate 12 and the lower substrate 11 are aligned (process c).

[0008]

Next, the suction mechanism 19 is vertically lowered so that the upper substrate 12 is brought into contact with the lower substrate 11 by means of the adhesive 14, and pressurized until the interval between the two substrates becomes 5 μm (process d). Thereafter, the joined lower and upper substrates 11 and 12 are fixed by a vacuum suction force of a suction mechanism 20 and transferred out from the vacuum container C (process e). Next, ultraviolet rays 16 are irradiated to cure the adhesive 14, and thus the joining of the lower substrate 11 and upper substrate 12 is completed.

[0009]

[Problems to be Solved by the Invention]

However, in the conventional method, since the vacuum suction is performed on the upper substrate 12 in the vacuum container, a wide suction area is required to ensure the vacuum suction force. For example, a glass having the upper substrate with a thickness of 0.7 mm requires 70% of aperture ratio. Accordingly, the suction force becomes

excessive when fixing the whole upper surface of the upper substrate 12 by the vacuum suction force of the suction mechanism 19 at atmospheric pressure. As a result, the upper substrate 12 is brought into abrupt contact with the suction mechanism 19, which leads to a problem of possible destruction of the upper substrate 12.

[0010]

Also, point suction by using a suction pad is applied when the lower substrate 11 and upper substrate 12 are joined and pressurized so that the interval between the substrates becomes 5 μm , and thus the joined lower substrate 11 and upper substrate 12 are transferred out from the vacuum container C by the vacuum suction force of the suction mechanism 20. Thus, as shown in the process e of Fig. 10, the lower substrate 11 and upper substrate 12 are distorted, which leads to a position deviation of the lower substrate 11 and the upper substrate 12.

[0011]

Also, since the joined lower substrate 11 and upper substrate 12 are transferred out from the vacuum container C by the vacuum suction force of the suction mechanism 20 and irradiated by the ultraviolet rays to cure the adhesive by means of a separate unit, the lower substrate 11 and upper substrate 12 are distorted during moving the substrates. Thus, the positional deviation occurs in the lower substrate

11 and the upper substrate 12.

[0012]

An object of the present invention is to provide an apparatus for manufacturing a liquid crystal display device capable of precisely joining two substrates which are arranged so as to be opposed to each other without destruction of the substrates.

[0013]

[Means for Solving the Problems]

According to the present invention, there is provided an apparatus for manufacturing a liquid crystal display device in which a lower substrate whose upper surface is coated with an adhesive and to which a liquid crystal material is dropped is arranged in a vacuum container at atmospheric pressure, the whole lower surface is fixed by vacuum suction, an upper substrate is arranged so as to be opposed to the lower substrate at a prescribed interval, the whole upper surface is fixed by vacuum suction, both the substrates or either one of them are approached so as to bring into contact with each other, and both the substrates are pressurized to join the substrates, wherein a plurality of suction systems are equipped in a suction mechanism which performs vacuum suction on the whole upper surface of the upper substrate so that suction force can be controlled when fixing the upper substrate at atmospheric pressure. Thus,

possible destruction of the upper substrate can be prevented when the upper substrate is brought into contact with a suction mechanism.

[0014]

Both suction systems are constructed so as to have a suction hole whose aperture ratio in vacuum is larger than at atmospheric pressure.

[0015]

According to the present invention, there is also provided a method for manufacturing a liquid crystal display device in which a lower substrate whose upper surface is coated with an adhesive and to which a liquid crystal material is dropped is arranged in a vacuum container at atmospheric pressure, the whole lower surface is fixed by vacuum suction, an upper substrate is arranged so as to be opposed to the lower substrate at a prescribed interval, the whole upper surface is fixed by vacuum suction, both the substrates or either one of them are approached so as to bring into contact with each other, and both the substrates are pressurized to join the substrates, wherein a plane-controlled suction transfer mechanism controls the whole surface of the substrates to be a flat plane at atmospheric pressure so that the joined lower substrate and upper substrate can be transferred out from the vacuum container without generating distortion of the substrates. Thus, the

positional deviation of the upper substrate and the lower substrate can be avoided.

[0016]

According to the present invention, there is also provided a method for manufacturing a liquid crystal display device in which a lower substrate whose upper surface is coated with an adhesive and to which a liquid crystal material is dropped is arranged in a vacuum container at atmospheric pressure, the whole lower surface is fixed by vacuum suction, an upper substrate is arranged so as to be opposed to the lower substrate at a prescribed interval, the whole upper surface is fixed by vacuum suction, both the substrates or either one of them are approached so as to bring into contact with each other, and both the substrates are pressurized to join the substrates, wherein the adhesive is cured in the vacuum container after pressurizing the upper substrate and the lower substrate. Since the adhesive is cured in the vacuum container after pressurizing the upper substrate and the lower substrate, and then transferred from the vacuum container, the positional deviation of the upper substrate and the lower substrate can be avoided.

[0017]

The adhesive is preferably cured by means of irradiating the ultraviolet rays and curing the adhesive at

atmospheric pressure, but a vacuum curing is also appropriate.

[0018]

[Description of the Embodiments]

Hereinafter, an apparatus for manufacturing a liquid crystal display device according to a first embodiment of the present invention will be described with reference to Figs. 1 and 2.

[0019]

First, a lower substrate 3 whose upper surface is coated with an ultraviolet ray curing type adhesive 1 with a thickness of 30 μm and to which a liquid crystal material 2 is arranged in the adhesive 1 is mounted on a horizontally movable table 4, and the whole lower surface of the lower substrate 3 is fixed by a vacuum suction force of a suction mechanism 5 (process a).

[0020]

Next, the upper surface of an upper substrate 6 consisting of light-penetration material is arranged so as to be opposed to the lower substrate 3, and fixed by a vacuum suction force of a suction mechanism 7 (process b). Here, the suction fixation is carried out by only the first suction system 7a of the suction mechanism 7. Then, additional suction fixation is carried out by the second suction system 7b, the aperture ratio of a suction hole is

enlarged, and the whole surface of the upper substrate 6 is fixed by the first and the second suction systems 7a and b (process c).

[0021]

Next, a vacuum container C is closed and evacuated and then both or either of the substrates 3 and 6 are aligned in vacuum so as to be opposed to each other (operation 6). Then, both or either of the substrates 3 and 6 are approached to each other so as to be pressurized and then joined (process e).

[0022]

Next, the joined both substrates 3 and 6 is transferred out from the vacuum container C, ultraviolet rays are irradiated by an ultraviolet irradiation method 8 to cure an adhesive 1, and the joining of the lower substrate 3 and the upper substrate 6 is completed (process f).

[0023]

According to the first embodiment of the present invention, when fixing the whole upper surface of the upper substrate 6 by the vacuum suction force of the suction mechanism 7 at atmospheric pressure, the suction force can be controlled by using only the first suction system 7a. As a result, the upper substrate 6 is no longer brought into abrupt contact with the suction mechanism 7a and b, and thus the possible destruction of the upper substrate 6 is removed.

Also, suction fixation in vacuum is surely ensured, since it is carried out by the first and the second suction systems 7a and b.

[0024]

Next, an apparatus for manufacturing a liquid crystal display device according to a second embodiment of the present invention will be described with reference to Figs. 3 and 4.

[0025]

First, a lower substrate 3 whose upper surface is coated with an ultraviolet ray curing type adhesive 1 with a thickness of 30 μm and to which a liquid crystal material 2 is arranged in the adhesive 1 is mounted on a horizontally movable table 4, and the whole lower surface of the lower substrate 3 is fixed by a vacuum suction force of a suction mechanism 5 (process a).

[0026]

Next, the upper surface of an upper substrate 6 consisting of light-penetration material is fixed by a vacuum suction force of a suction mechanism 7 (process b). Next, a vacuum container C is closed and evacuated and then both or either of the substrates 3 and 6 are aligned in vacuum so as to be opposed to each other (process c). Then, both or either of the substrates 3 and 6 are approached to each other so as to be pressurized and then joined (process

d).

[0027]

Next, a vacuum suction is performed on the joined both substrates 3 and 6 by a suction transfer mechanism 9 which controls the whole surface of the substrates to be a flat panel. Then the substrates are transferred out from the vacuum container C. Next, ultraviolet rays are irradiated by an ultraviolet irradiation method 8 to cure an adhesive 1, and the joining of the lower substrate 3 and the upper substrate 6 is completed (process f).

[0028]

According to the second embodiment of the present invention, the lower substrate 3 and the upper substrate 6 are joined and pressurized so that the interval between the lower and upper substrates becomes 5 μm . Since the vacuum suction is performed on the joined substrates 3 and 6 by the suction transfer mechanism 9 which controls the whole surface of the substrates to be a flat panel, the possible distortion of the lower substrate 3 and upper substrate 6 during transferring is removed. Thus, the positional deviation of the upper substrate and the lower substrate can be avoided.

[0029]

Next, an apparatus for manufacturing a liquid crystal display device according to a third embodiment of the

present invention will be described with reference to Figs. 5 and 6.

[0030]

First, a lower substrate 3 whose upper surface is coated with an ultraviolet ray curing type adhesive 1 with a thickness of 30 μm and to which a liquid crystal material 2 is arranged in the adhesive 1 is mounted on a horizontally movable table 4, and the whole lower surface of the lower substrate 3 is fixed by a vacuum suction force of a suction mechanism 5 (process a).

[0031]

Next, the upper surface of an upper substrate 6 consisting of light-penetration material is fixed by a vacuum suction force of a suction mechanism 7 (process b). Next, a vacuum container C is closed and evacuated and then both or either of the substrates 3 and 6 are aligned in vacuum so as to be opposed to each other (process c). Then, both or either of the substrates 3 and 6 are approached to each other so as to be pressurized and then joined (process d).

[0032]

Next, on the table 4 in the vacuum container C, the joined substrates 3 and 6 remain fixed by the suction fixation, ultraviolet rays are irradiated by an ultraviolet irradiation method 8 to cure an adhesive 1, and the joining

of the lower substrate 3 and the upper substrate 6 is completed (process e). Thereafter, the substrates are removed from the vacuum container C and transferred by a transfer means (not shown).

[0033]

According to the third embodiment of the present invention, the lower substrate 3 and the upper substrate 6 are joined and pressurized so that the interval between the lower and upper substrates becomes 5 μm . Next, on the joined lower substrate 3 and upper substrate 6, the ultraviolet rays are irradiated by the ultraviolet irradiation method installed in the same apparatus to cure the adhesive 1. Thus, the possible distortion of the lower substrate 3 and upper substrate 6 is removed and the positional deviation of the upper substrate and the lower substrate can be avoided. Also, the ultraviolet radiation may be performed in vacuum.

[0034]

[Advantages]

According to the first embodiment of the present invention, since a plurality of suction systems are equipped in the suction mechanism which performs vacuum suction on the whole surface of the upper substrate, the vacuum suction force can be controlled during the suction fixation of the whole upper surface of the upper substrate at atmospheric

pressure. Thus, it can be avoided that the upper substrate is brought into abrupt contact with the suction mechanism, which leads to the possible destruction of the upper substrate.

[0035]

Also, according to the second embodiment of the present invention, suction transfer is carried out by a panel-controlled suction transfer mechanism which controls the whole surface of the substrates to be a flat panel at atmospheric pressure. As a result, the lower substrate and upper substrate can be transferred out from the vacuum container without generating distortion. Thus, the positional deviation of the upper substrate and the lower substrate can be avoided.

[0036]

Also, according to the third embodiment of the present invention, a method of curing the adhesive in the vacuum container after pressuring the upper substrate and the lower substrate is installed. Since the adhesive is cured in the vacuum container after pressurizing the upper substrate and the lower substrate and then transferred out from the vacuum container, the positional deviation of the upper substrate and the lower substrate can be avoided.

[Brief Description of the Drawings]

[Fig. 1]

Fig. 1 is a schematic cross-sectional view of processes of an apparatus for manufacturing a liquid crystal display device according to a first embodiment of the present invention.

[Fig. 2]

Fig. 2 is a schematic cross-sectional view of the following processes of Fig. 1.

[Fig. 3]

Fig. 3 is a schematic cross-sectional view of processes of an apparatus for manufacturing a liquid crystal display device according to a second embodiment of the present invention.

[Fig. 4]

Fig. 4 is a schematic cross-sectional view of the following processes of Fig. 3.

[Fig. 5]

Fig. 5 is a schematic cross-sectional view of processes of an apparatus for manufacturing a liquid crystal display device according to a third embodiment of the present invention.

[Fig. 6]

Fig. 6 is a schematic cross-sectional view of the following processes of Fig. 5.

[Fig. 7]

Fig. 7 is a schematic cross-sectional view of structure

of a liquid crystal display device.

[Fig. 8]

Fig. 8 is a schematic cross-sectional view of manufacturing process of a liquid crystal display device

[Fig. 9]

Fig. 9 is a schematic cross-sectional view of processes of a conventional apparatus for manufacturing a liquid crystal display device.

[Fig. 10]

Fig. 10 is a schematic cross-sectional view of the following processes of Fig. 9.

[Reference Numerals]

- 1: adhesive
- 2: liquid crystal material
- 3: lower substrate
- 5: suction mechanism
- 6: upper substrate
- 7: suction mechanism
- 7a: first suction system
- 7b: second suction system
- 8: ultraviolet ray irradiation method
- 9: plane-controlled suction transfer mechanism
- C: vacuum container

(51)Int. Cl. ⁷	識別記号	F I	テ-マコード (参考)
G02F 1/13	101	G02F 1/13	2H088
B05C 13/02		B05C 13/02	4D075
B05D 3/06	102	B05D 3/06	Z 4F042
7/24	301	7/24	P 5F031
H01L 21/68		H01L 21/68	B
		審査請求	未請求 請求項の数 9 O L (全8頁)

(21)出願番号 特願平11-121236

(22)出願日 平成11年4月28日(1999.4.28)

(71)出願人 000005821

松下電器産業株式会社

大阪府門真市大字門真1006番地

(72)発明者 江上 典彦

大阪府門真市大字門真1006番地 松下電器
産業株式会社内

(74)代理人 100080827

弁理士 石原 勝

最終頁に続く

(54)【発明の名称】 液晶表示素子製造装置および方法

(57)【要約】

【課題】 対向する位置に配置された2枚の基板を破損することなく精度良く貼り合わせることができる液晶表示素子製造装置を提供する。

【解決手段】 上面に接着剤1が塗布され液晶材料2が滴下された下基板3を大気雰囲気中にて真空容器C内に配置して下側の全面を真空吸着で固定し、下基板3に対向するように所定の間隔で上基板6を配置して上側の全面を真空吸着して固定し、真空雰囲気中にて両方又は一方の基板3、6を接近移動させて相互に加圧し、両基板3、6を貼り合わせるようにした液晶表示素子製造装置において、上基板6の上側全面を真空吸着する吸着機構7に複数の吸着系統7a、7bを設けて、大気中で上基板6を吸着固定する時の吸着力を抑制し、上基板6の破損を防止するようにした。

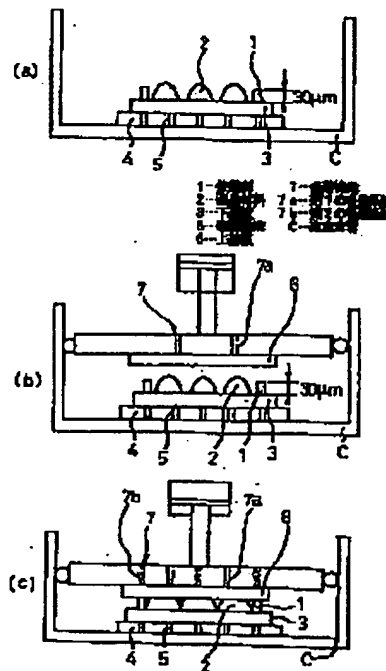

【特許請求の範囲】

【請求項1】 上面に接着剤が塗布され液晶材料が滴下された下基板を大気雰囲気中にて真空容器内に配置して下側の全面を真空吸着で固定し、下基板に対向するように所定の間隔で上基板を配置して上側の全面を真空吸着して固定し、真空雰囲気中にて両方又は一方の基板を接近移動させて相互に加圧し、両基板を貼り合わせるようにした液晶表示素子製造装置において、上基板の上側全面を真空吸着する吸着機構に複数の吸着系統を設けたことを特徴とする液晶表示素子製造装置。

【請求項2】 両吸着系統は、大気圧中での吸着穴開口率よりも真空中での吸着穴開口率が大きくなるように構成したことを特徴とする請求項1記載の液晶表示素子製造装置。

【請求項3】 上面に接着剤が塗布され液晶材料が滴下された下基板を大気雰囲気中にて真空容器内に配置して下側の全面を真空吸着で固定し、下基板に対向するように所定の間隔で上基板を配置して上側の全面を真空吸着して固定し、真空雰囲気中にて両方又は一方の基板を接近移動させて相互に加圧し、両基板を貼り合わせるようにした液晶表示素子製造装置において、大気中で基板全面を平面で規制して吸着搬送する平面規制吸着搬送機構を設けたことを特徴とする液晶表示素子製造装置。

【請求項4】 上面に接着剤が塗布され液晶材料が滴下された下基板を大気雰囲気中にて真空容器内に配置して下側の全面を真空吸着で固定し、下基板に対向するように所定の間隔で上基板を配置して上側の全面を真空吸着して固定し、真空雰囲気中にて両方又は一方の基板を接近移動させて相互に加圧し、両基板を貼り合わせるようにした液晶表示素子製造装置において、上基板と下基板を加圧した後真空容器内で接着剤を硬化する手段を設けたことを特徴とする液晶表示素子製造装置。

【請求項5】 接着剤を硬化する手段が紫外線照射手段を備えることを特徴とする請求項4記載の液晶表示素子製造装置。

【請求項6】 接着剤を硬化する手段を大気中で接着剤を硬化するようにしたことを特徴とする請求項4記載の液晶表示素子製造装置。

【請求項7】 上面に接着剤が塗布され液晶材料が滴下された下基板を大気雰囲気中にて真空容器内に配置して下側の全面を真空吸着で固定し、下基板に対向するように所定の間隔で上基板を配置して上側の全面を真空吸着して固定し、真空雰囲気中にて両方又は一方の基板を接近移動させて相互に加圧し、両基板を貼り合わせるようにした液晶表示素子製造方法において、複数の吸着系統を設けた吸着機構によって上基板の上側全面を真空吸着することを特徴とする液晶表示素子製造方法。

【請求項8】 上面に接着剤が塗布され液晶材料が滴下された下基板を大気雰囲気中にて真空容器内に配置して下側の全面を真空吸着で固定し、下基板に対向するよう

に所定の間隔で上基板を配置して上側の全面を真空吸着して固定し、真空雰囲気中にて両方又は一方の基板を接近移動させて相互に加圧し、両基板を貼り合わせるようにした液晶表示素子製造方法において、平面規制吸着搬送機構によって、大気中で基板全面を平面で規制して吸着搬送することを特徴とする液晶表示素子製造方法。

【請求項9】 上面に接着剤が塗布され液晶材料が滴下された下基板を大気雰囲気中にて真空容器内に配置して下側の全面を真空吸着で固定し、下基板に対向するように所定の間隔で上基板を配置して上側の全面を真空吸着して固定し、真空雰囲気中にて両方又は一方の基板を接近移動させて相互に加圧し、両基板を貼り合わせるようにした液晶表示素子製造方法において、上基板と下基板を加圧した後真空容器内で接着剤を硬化することを特徴とする液晶表示素子製造方法。

【発明の詳細な説明】

【0001】

【発明の属する技術分野】本発明は、パーソナルコンピュータやTV受像機等の画像表示パネルとして用いられる液晶表示素子の製造装置および方法に関するものである。

【0002】

【従来の技術】従来の液晶表示素子の製造装置について、図7～図10を参照して説明する。

【0003】液晶表示素子の構造は、図7に示すように、対向配置された透光性材料からなる下基板11と上基板12との間に一定ギャップを保つとともに、その間の空間に液晶材料13を充填した状態で両者が紫外線硬化型の接着剤14にて貼り合わされている。接着剤14には下基板11と上基板12の間隔を一定に保つためのスペーサ15（径5 μ m）が含まれている。

【0004】このように液晶材料13を接着剤14の内側に配置する一方法として、図8に示すように、下基板11に接着剤14を厚み30 μ mで塗布した後（工程a）、接着剤14の内側に液晶材料13を滴下し（工程b）、次に上基板12を重ね合わせて上基板12と下基板11の間隔が5 μ mになるまで加圧し（工程c）、その後紫外線16により接着剤14を硬化させ（工程d）、液晶表示素子を完成させる液晶滴下工法が知られている。

【0005】以下、上記2枚の基板の貼り合わせ方法について、図9、図10を参照して説明する。

【0006】まず、表面に紫外線硬化型の接着剤14が厚み30 μ mで塗布され、その接着剤14の内側に液晶材料13が配置された透光性材料からなる下基板11を、水平方向に移動可能なテーブル17上に搭載し、下基板11の下側の全面を吸着機構18による真空吸着で固定する（工程a）。

【0007】次に、透光性材料からなる上基板12の上側の全面を吸着機構19による真空吸着で固定し、真空

容器Cを閉じて真空引きを行い、吸着機構19を垂直方向に下降させて、上基板12と液晶材料13または接着剤14を接触させる(工程b)。次に、下基板11を搭載したテーブル17を水平方向に移動させて、下基板11と上基板12の位置合わせを行う(工程c)。

【0008】次に、吸着機構19を垂直方向に下降させ、上基板12を接着剤14を介して下基板11に貼り合わせ、5 μ mまで加圧させる(工程d)。その後、一体となった下基板11と上基板12を吸着機構20により真空吸着して真空容器Cから取り出して搬送する(工程e)。次に、紫外線16を照射して接着剤を硬化させて下基板11と上基板12の貼り合わせが完了する(工程f)。

【0009】

【発明が解決しようとする課題】しかしながら、このような従来の装置では、真空容器の中で上基板の真空吸着を行うため、真空中での吸着力を確保するために広い吸着面積を要する。例えば、上基板の厚さが0.7mmのガラスの場合は70%の開口率を要する。そうすると、大気中で上基板12の上側の全面を吸着機構19で真空吸着して固定する時に吸着力が強すぎて、上基板12が吸着機構19に衝撃的に接触し、上基板12を破損するという問題があった。

【0010】また、下基板11と上基板12を貼り合わせ、5 μ mまで加圧し、一体となった下基板11と上基板12を吸着機構20による真空吸着で真空容器Cから取り出して搬送を行う時に、吸着パッド等による点吸着であるため、図10の工程eに図示のごとく、下基板11と上基板12が撓んでしまい、下基板11と上基板12とが位置ずれを起こすという問題があった。

【0011】また、一体となった下基板11と上基板12を吸着機構20による真空吸着で真空容器Cから取り出して搬送を行い、別の装置により紫外線を照射して接着剤を硬化させるため、その間の移動により下基板11と上基板12が撓んでしまい、下基板11と上基板12とが位置ずれを起こすという問題があった。

【0012】本発明は、上記従来の問題点に鑑み、対向する位置に配置された2枚の基板を破損することなく精度良く貼り合わせることができる液晶表示素子製造装置を提供することを目的としている。

【0013】

【課題を解決するための手段】本発明の第1発明は、上面に接着剤が塗布され液晶材料が滴下された下基板を大気雰囲気中にて真空容器内に配置して下側の全面を真空吸着で固定し、下基板に対向するように所定の間隔で上基板を配置して上側の全面を真空吸着して固定し、真空雰囲気中にて両方又は一方の基板を接近移動させて相互に加圧し、両基板を貼り合わせるようにした液晶表示素子製造装置において、上基板の上側全面を真空吸着する吸着機構に複数の吸着系統を設けたものであり、大気中

で上基板の上側の全面を吸着固定する時に吸着力を抑制できるので、上基板が吸着機構に衝撃的に接触して上基板が破損するのを防止できる。

【0014】両吸着系統は、大気中での吸着穴開口率よりも真空中での吸着穴開口率が大きくなるように構成される。

【0015】また、本発明の第2発明は、上面に接着剤が塗布され液晶材料が滴下された下基板を大気雰囲気中にて真空容器内に配置して下側の全面を真空吸着で固定し、下基板に対向するように所定の間隔で上基板を配置して上側の全面を真空吸着して固定し、真空雰囲気中にて両方又は一方の基板を接近移動させて相互に加圧し、両基板を貼り合わせるようにした液晶表示素子製造装置において、大気中で基板全面を平面で規制して吸着搬送する平面規制吸着搬送機構を設けたものであり、貼り合わせて一体となった下基板と上基板を撓みを生じさせることなく真空容器から搬送することができ、上基板と下基板の位置ずれを防止できる。

【0016】また、本発明の第3発明は、上面に接着剤が塗布され液晶材料が滴下された下基板を大気雰囲気中にて真空容器内に配置して下側の全面を真空吸着で固定し、下基板に対向するように所定の間隔で上基板を配置して上側の全面を真空吸着して固定し、真空雰囲気中にて両方又は一方の基板を接近移動させて相互に加圧し、両基板を貼り合わせるようにした液晶表示素子製造装置において、上基板と下基板を加圧した後真空容器内で接着剤を硬化する手段を設けたものであり、上基板と下基板を加圧した後真空容器内で接着剤を硬化し、その後に真空容器から搬送することにより上基板と下基板の位置ずれを防止できる。

【0017】接着剤を硬化する手段は、紫外線照射手段を備え、また大気中で接着剤を硬化するようにしたもののが好適であるが、真空中で硬化させてもよい。

【0018】

【発明の実施の形態】(第1の実施形態)本発明の第1の実施形態の液晶表示素子の製造装置について、図1、図2を参照して製造工程に沿って説明する。

【0019】まず、表面に厚み30 μ mで塗布された紫外線硬化型の接着剤1及びその接着剤1の内側に液晶材料2が配置された透光性材料からなる下基板3を、水平方向に移動可能なテーブル4上に搭載し、下基板3の下側の全面を大気中にて吸着機構5による真空吸着で固定する(工程a)。

【0020】次に、下基板3に対向するように所定間隔で、透光性材料からなる上基板6を配置し、この上基板6の上側面を大気中にて吸着機構7による真空吸着で固定する(工程b)。この時、吸着機構7の第1の吸着系統7aのみによって吸着固定する。次に、第2の吸着系統7bによる真空吸着を追加して吸着穴の開口率を大きくし、上基板6の全面を第1及び第2の吸着系統7a、

7 bにて吸着固定する(工程c)。

【0021】次に、真空容器Cを閉じて真空引きを行い、真空雰囲気中にて両方又は一方の基板3、6を基板の対向方向に相対移動させて位置合わせを行う(工程d)。次に、両方又は一方の基板3、6を接近移動させて相互に加圧し、両基板3、6を貼り合わせる(工程e)。

【0022】その後、貼り合わせた両基板3、6を真空容器Cの外部に搬送し、紫外線照射手段8にて紫外線を照射して接着剤1を硬化させて、下基板3と上基板6の貼り合わせが完了する(工程f)。

【0023】本実施形態によれば、大気中で上基板6の上側の全面を吸着機構7による真空吸着で固定する時に、第1の吸着系統7 aのみで吸着することで吸着力を抑制できるので、上基板6が吸着機構7 a及び7 bに衝撃的に接触することがなく、上基板6を破損することがなくなる。また、真空雰囲気中では第1と第2の吸着系統7 a、7 bで吸着固定するので、確実に固定される。

【0024】(第2の実施形態)次に、本発明の第2の実施形態の液晶表示素子の製造装置について、図3、図4を参照して製造工程に沿って説明する。

【0025】まず、表面に厚み30 μ mで塗布された紫外線硬化型の接着剤1及びその接着剤1の内側に液晶材料2が配置された透光性材料からなる下基板3を、水平方向に移動可能なテーブル4上に搭載し、下基板3の下側の全面を大気圧中にて吸着機構5による真空吸着で固定する(工程a)。

【0026】次に、下基板3に対向するように所定間隔で、透光性材料からなる上基板6の上側の全面を吸着機構7による真空吸着で固定する(工程b)。次に、真空容器Cを閉じて真空引きを行い、真空雰囲気中にて、両方又は一方の基板3、6を基板の対向方向に相対移動させて位置合わせを行う(工程c)。次に、両方又は一方の基板3、6を接近移動させて相互に加圧し、両基板3、6を貼り合わせる(工程d)。

【0027】次に、貼り合わせた両基板3、6の基板全面を平面規制した状態で吸着する平面規制吸着搬送機構9にて真空吸着して真空容器Cの外部に搬送する(工程e)。次に、紫外線照射手段8にて紫外線を照射して接着剤1を硬化させて、下基板3と上基板6の貼り合わせが完了する(工程f)。

【0028】本実施形態によれば、下基板3と上基板6を貼り合わせ、5 μ mまで加圧後、一体となった下基板3と上基板6を平面規制吸着搬送機構9にて吸着して真空容器Cから取り出して搬送するので、搬送中に下基板3と上基板6が撓むことがなく、位置ずれを起こすことがない。

【0029】(第3の実施形態)次に、本発明の第3の実施形態の液晶表示素子の製造装置について、図5、図6を参照して製造工程に沿って説明する。

10

【0030】まず、表面に厚み30 μ mで塗布された紫外線硬化型の接着剤1及びその接着剤1の内側に液晶材料2が配置された透光性材料からなる下基板3を、水平方向に移動可能なテーブル4上に搭載し、下基板3の下側の全面を大気圧中にて吸着機構5による真空吸着で固定する(工程a)。

【0031】次に、下基板3に対向するように所定間隔で、透光性材料からなる上基板6の上側の全面を吸着機構7による真空吸着で固定する(工程b)。次に、真空容器Cを閉じて真空引きを行い、真空雰囲気中にて、両方又は一方の基板3、6を基板の対向方向に相対移動させて位置合わせを行う(工程c)。次に、両方又は一方の基板3、6を接近移動させて相互に加圧し、両基板3、6を貼り合わせる(工程d)。

【0032】次に、真空容器C内のテーブル4上で、貼り合わされた両基板3、6が吸着固定された状態で紫外線照射手段8にて紫外線を照射して接着剤1を硬化させて、下基板3と上基板6の貼り合わせが完了する(工程e)。その後、適宜搬送手段(図示せず)にて真空容器Cから取り出して搬送される。

20

【0033】本実施形態によれば、下基板3と上基板6を貼り合わせ、5 μ mまで加圧後、一体となった下基板3と上基板6に対して、同じ装置に設置した紫外線照射手段8にて紫外線を照射して接着剤1を硬化させるため、下基板3と上基板6が撓むことがなく、位置ずれを起こすことがない。なお、紫外線照射は、真空加圧中に行ってもよい。

【0034】

30

【発明の効果】本発明の第1発明によれば、上基板の上側全面を真空吸着する吸着機構に複数の吸着系統を設けたので、大気中で上基板の上側の全面を吸着固定する時に吸着力を抑制できるので、上基板が吸着機構に衝撃的に接触して上基板が破損するのを防止できる。

【0035】また、第2発明によれば、大気中で基板全面を平面で規制して吸着搬送する平面規制吸着搬送機構を設けたので、貼り合わせて一体となった下基板と上基板を撓みを生じさせることなく真空容器から搬送することができ、上基板と下基板の位置ずれを防止できる。

40

【0036】また、第3発明によれば、上基板と下基板を加圧した後真空容器内で接着剤を硬化する手段を設けたので、上基板と下基板を加圧した後真空容器内で接着剤を硬化し、その後に真空容器から搬送することにより上基板と下基板の位置ずれを防止できる。

【図面の簡単な説明】

【図1】本発明の第1の実施形態の液晶素子製造装置による製造工程を示す模式断面図である。

【図2】同実施形態の製造工程の続きを示す模式断面図である。

50

【図3】本発明の第2の実施形態の液晶素子製造装置による製造工程を示す模式断面図である。

【図4】同実施形態の製造工程の続きを示す模式断面図である。

【図5】本発明の第3の実施形態の液晶素子製造装置による製造工程を示す模式断面図である。

【図6】同実施形態の製造工程の続きを示す模式断面図である。

【図7】液晶表示装置の構造を示す模式断面図である。

【図8】液晶表示装置の製造工程を示す模式断面図である。

【図9】従来例の液晶表示装置の製造工程を示す模式断面図である。

【図10】同従来例の液晶表示装置の製造工程の続きを示す模式断面図である。

【符号の説明】

- 1 接着剤
- 2 液晶材料
- 3 下基板
- 5 吸着機構
- 6 上基板
- 7 吸着機構
- 7 a 第1の吸着系統
- 7 b 第2の吸着系統
- 8 紫外線照射手段
- 9 平面規制吸着搬送機構
- C 真空容器

【図1】

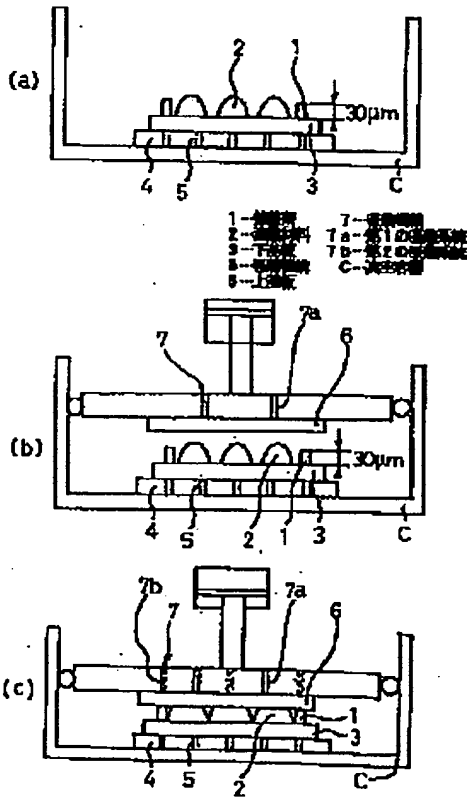

【図2】

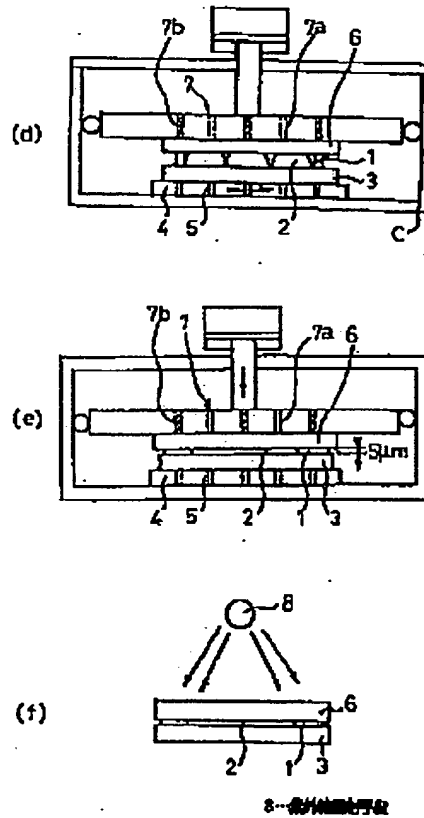

【図7】



【図3】

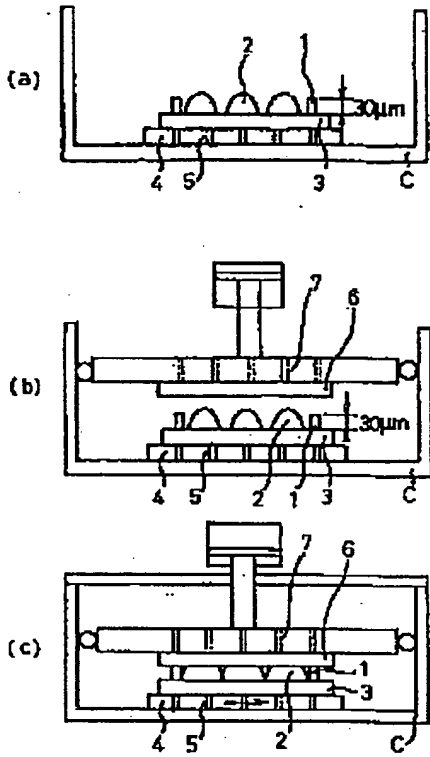

【図4】

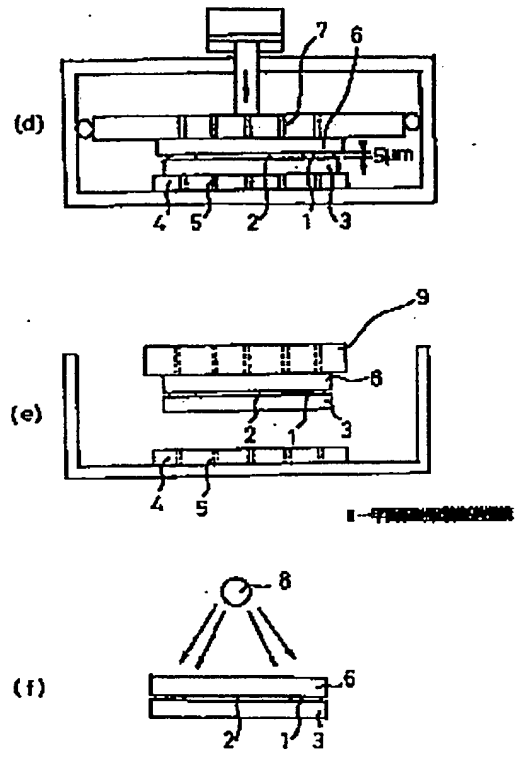

【図6】

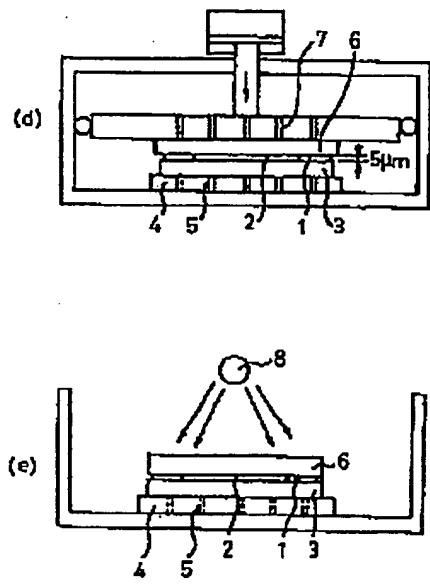

【図8】

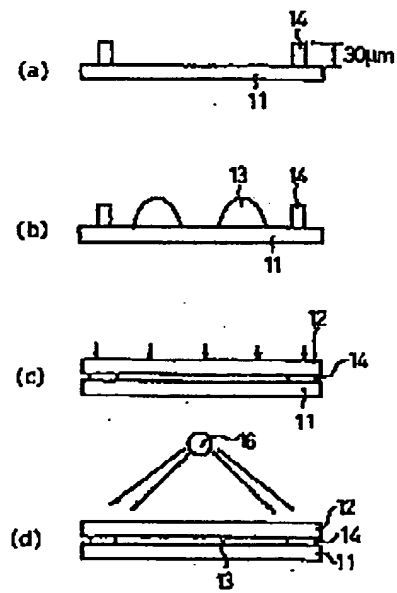

【図5】

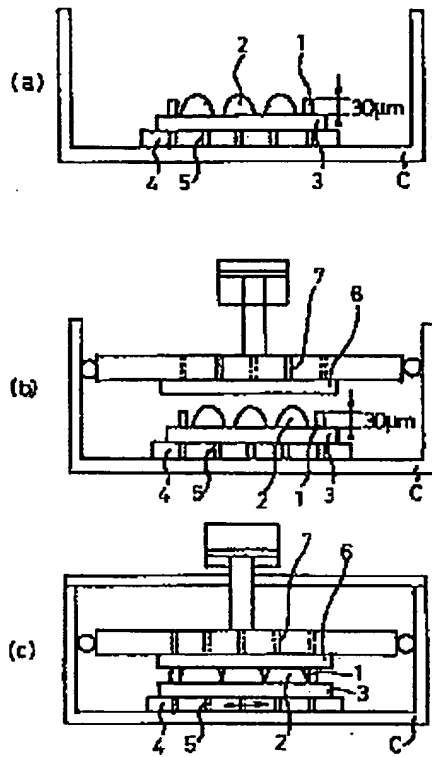

【図9】

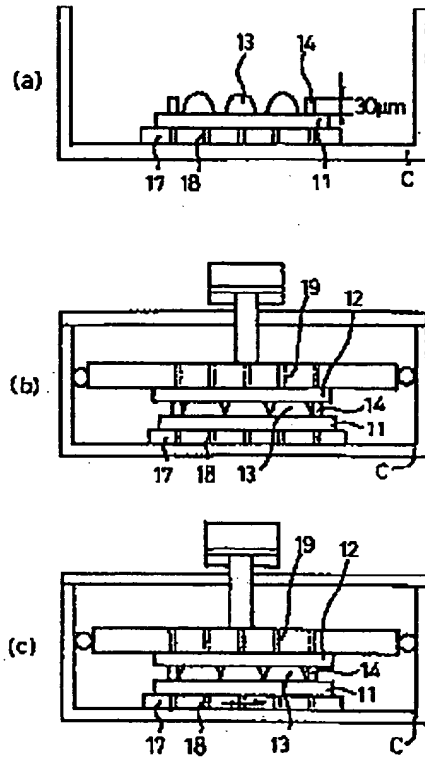

【図10】

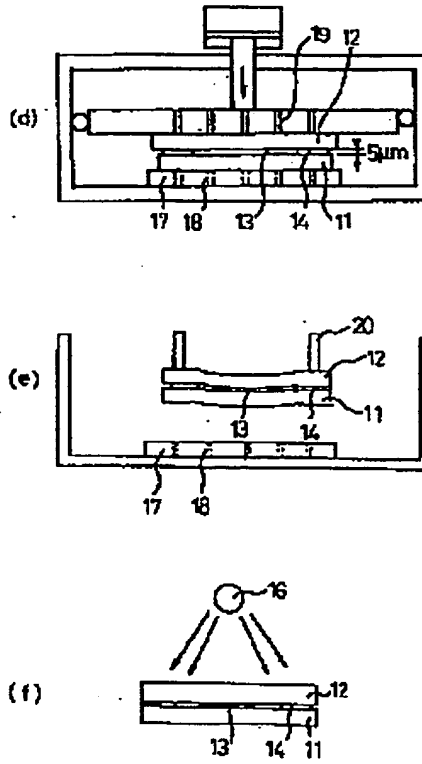

フロントページの続き

Fターム(参考) 2H088 EA02 FA03 FA04 FA16 FA17
FA20 FA30 HA01 KA02 MA17
MA20
4D075 AC06 AC82 AC88 BB46Z
CA47 DA06 DB11 DC19 DC22
EA21 EA35
4F042 AA06 BA06 DB41 DF09
5F031 CA05 GA08